

## Flat display interface PFI 3040

### Specifications

---

- Screen size (Min. - Max.): 19 – 32 " / 48 – 81 cm
- Max. weight: 30 kg / 66 lbs
- Guarantee: 5 years
- Available colours: Black

The PFI 3040 display interface is a part of the modular Connect-it system with which you can create your own ceiling solution for small- to medium-sized displays.



## Flat display interface PFI 3040

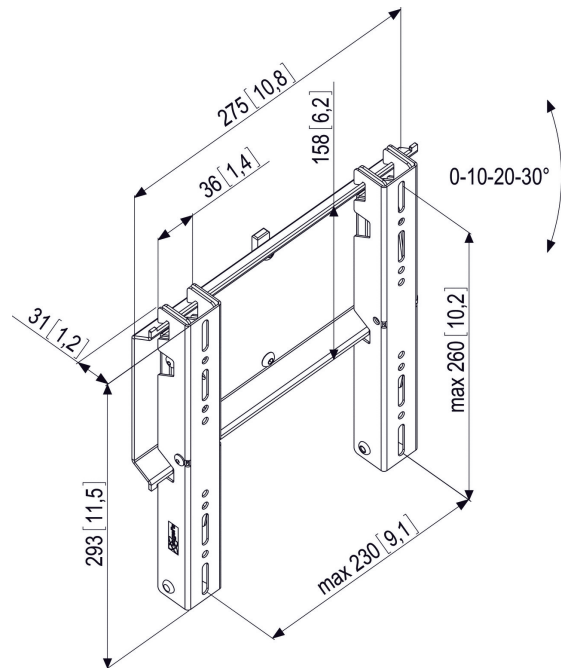

The PFI 3040 is suitable for small- to medium-sized displays (max. 230x260 mm hole pattern) up to 30 kg. This interface has an incremental tilting function (0-10-20-30°), a variable height setting and is theft-delaying. Multiple displays can be installed one on top of each other and/or back-to-back. Combine this display interface with one of the Connect-it ceiling plates (PUC 1010, PUC 1030 or PUC 1040) or the truss adapter (PUC 1050) and one of the poles from the Connect-it Series (PUC 2308, PUC 2315 or PUC 2330) for a complete ceiling solution.

## Features

- Fits on PUC 23xx poles
- 0-10-20-30° tilt function
- Non VESA up to 230x260 mm
- Quick and easy installation

## Logistic information

- Packaging size: 178x318x81 mm
- Max. weight: 3 kg / 7 lbs
- EAN Code: 8712285317323