



For Sure

# RISE

## Motorized Display Lift Systems



**WHY**  
RISE

**WHAT**  
is RISE

**WHITE-  
BOARDS**  
for RISE

**RISE**  
accessories



**WHY  
RISE**

## WHY RISE

A complete range of motorized display lift systems that allows you to intuitively and safely set a screen in the right place and at the right height. Moving a motorized lift system should go without thinking, with your hand on the screen and your mind on the story.

Thanks to the quality components, high-end design and highest international safety standards, your installation will RISE to the next level.



# WHY RISE

- RISE is a complete line-up of motorized lit systems
- RISE meets the highest international safety standards as TÜV 5, UL, GS, CE & ADA.
- RISE has the fastest actuators, even with full load capacity.
- RISE is easy and fast to install .
- RISE is durable, up to 30.000 cycles.
- RISE is sustainable. The products are packed in a single cardboard box with no plastic or PU foam.
- RISE is an attractively priced premium product.



# RISE Complete line-up

Floor wall solutions, trolleys and floor stands.

Specifically designed to accommodate for large displays up to 98 inches or 105 inch stretch

Maximum weight 120 kg for trolleys and 140 kg for wall lifts.

All products available in black, floor wall solutions also available in white.

A full line-up of accessories, including universal whiteboards





# RISE safety standards

Safety is paramount at Vogel's.

- Tested up to 5 times the specified maximum load (TUV 5).
- Tested up to 10 degrees tilting angle, even with Whiteboards mounted.
- RISE 2XXX, 3XXX and 4XXX are ADA compliant
- RISE 2XXX, 3XXX and 5XXX are UL compliant
- All products 5-year guarantee.





# RISE has fastest actuators in the market

RISE offers the fastest actuators in the market, even with fully loaded weight capacity:

- Competition also claims 50 or 80 mm/s or even more, but do they also reach this with full capacity? The answer is no.



# RISE is easy and fast to install

The RISE Series are designed with easy and fast installation in mind.

- Top-down installation - all fasteners are accessible from the top of the lift system.
- Professional manual and trustworthy documentation
- Additional power cable connector in lift base to attach a power cord to.
- Total time to install lift is around 20 minutes (with whiteboards an additional 15 minutes).

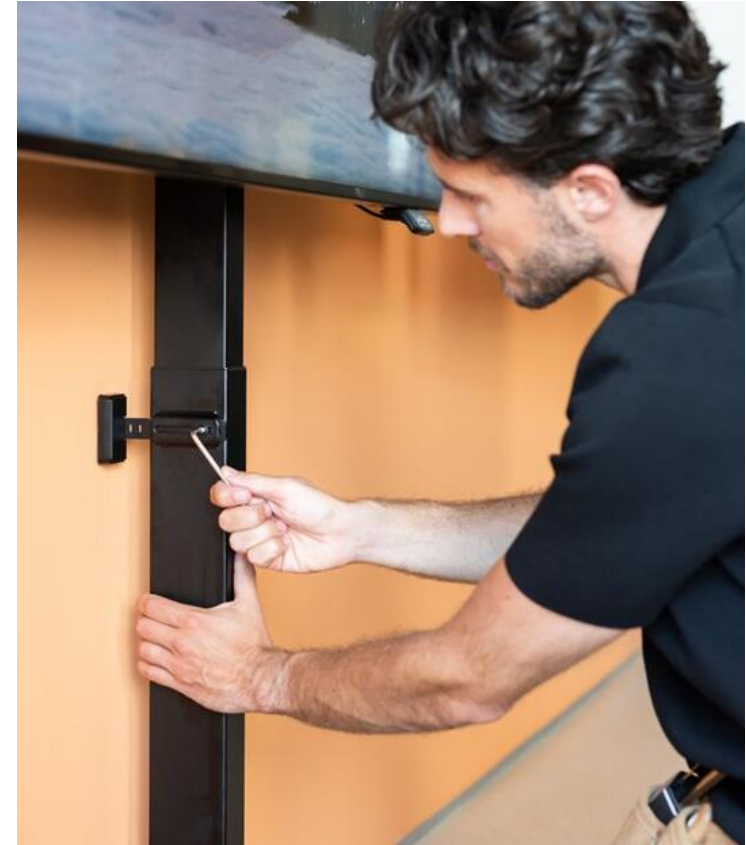

# RISE is durable

At Vogel's we believe that the best way to preserve the environment is to make products that will last a very long time.

- Use of only high-quality components and materials.
- Endurance tested more than 30.000 cycles.

## **Sustainable design**

Endurance tested design of more than 30,000 cycles



# RISE is sustainable

- Vogel's is B-Corp certified.
- Packed in one compact carton delivery box.
- No plastics or PU foam used.
- Total weight of waste is only 4300 grams of cardboard per lift.



## RISE safety - ChildLock and anti-collision

A child lock feature is integrated as standard in all RISE Series motorized lift systems which keeps the youngest pupils safe in an unsupervised moment.

- ChildLock keeps children away from operating the lift
- The ChildLock feature enables you to easily lock the lift system when needed.
- ChildLock automatically switches on after 5 minutes
- ChildLock can be disabled permanently if desired
- All products do have an anti-collision safety mechanism







**WHAT**  
is RISE

# 2000 Series

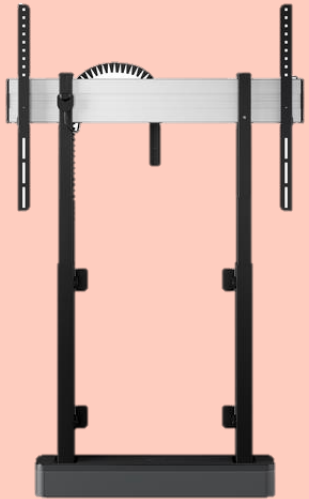

# 3000 Series

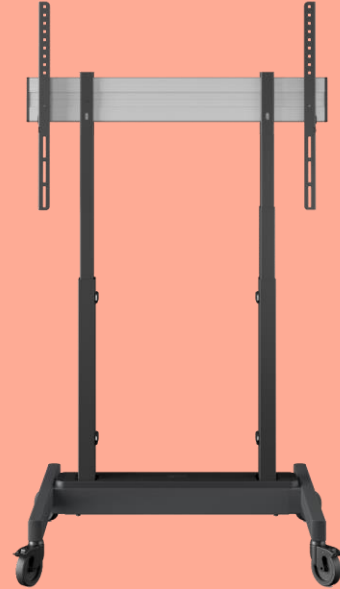

# 4000 Series

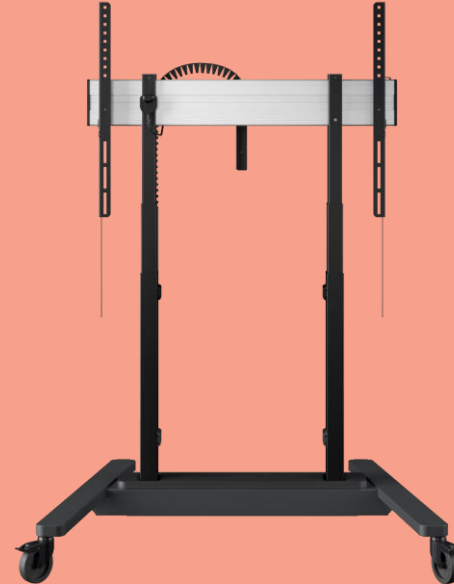

# 5000 Series





## RISE 2000 Series – Floor supported wall mounts



- Displays up to 98"
- Max. 140KG
- 985 mm stroke
- 50mm/s or 80mm/s
- Available in black and white
- Cable management
- Whiteboards up to 86"
- Wide range of accessories
- Anti-collision
- CE, TUV, UL, GS & ADA certified



## RISE 3000 Series – Economy trolley



- Displays up to 86"
- Max. 100KG
- 700 mm stroke
- 50mm/s
- H-frame, basic wheels
- Available in black
- No cable management
- No whiteboards
- Range of accessories
- Anti-collision
- CE, TUV, UL & ADA certified



## RISE 4000 Series – Flexible mid range trolleys & stands



- Displays up to 86"
- Max. 120KG
- 700 mm stroke
- 50mm/s or 80mm/s
- Open H-frame, basic wheels
- Available in black
- Cable management
- Whiteboards up to 86"
- Wide range of accessories
- Anti-collision
- CE, TUV, GS & ADA certified



## RISE 5000 Series – Ergonomic premium range trolleys



- Displays up to 98"
- Max. 120KG
- 985 mm stroke
- 50mm/s or 80mm/s
- High end aluminum ring frame
- Available in black
- Cable management
- Whiteboards up to 86"
- Wide range of accessories
- Anti-collision
- CE, TUV, UL & GS certified



# RISE Line-up video



# RISE Current product line-up

	2000-Series	3000-Series	4000-Series	5000-Series
50mm	RISE 2005B RISE 2005W	RISE 3205	RISE 4205	RISE 5205 RISE 5305*
80mm	RISE 2008B RISE 2008W		RISE 4208	RISE 5208 RISE 5308*

\*RISE 5305 & RISE 5308 will become an made to order product, without stock.





**WHITE  
BOARDS**  
for RISE



# Universal Whiteboards sets for RISE

All\* RISE motorized lift systems can be combined with the **RISE Whiteboard sets**

- 3 sizes: 65, 75 & 86 inch
- Friction hinge
- Large whiteboards
- Magnetic closure
- Height adjustable
- Depth adjustable
- Option for print
- 15 minutes installation-time

\*except for RISE 3205



# 2000

**RISE WBS65**  
**RISE WBS75**  
**RISE WBS86**

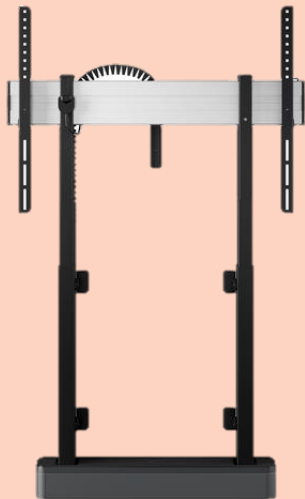

# 4000

**RISE WBS65**  
**RISE WBS75**  
**RISE WBS86**

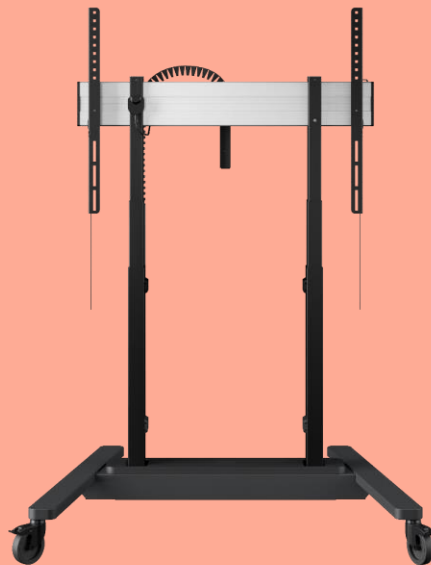

No counterweights needed

# 5000

**RISE WBS65M**  
**RISE WBS75M**  
**RISE WBS86M**



Including 1 or 2 counterweights



# RISE Accessories

# Storages and hardware brackets

- Hidden storage (RISE A311)
- Hidden storage bar extender (RISE A321)
- Power socket EU (RISE A152) – Power supplied by Y-cable
- Installer cable (RISE A151) – for installer software
- Mounting bracket mini-PC / NUC etc. (RISE A122)

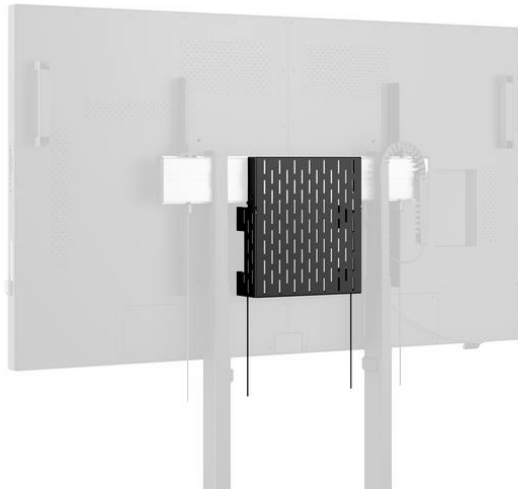

Hidden storage RISE A311



Hidden storage with bar extender RISE A311 + A321



Mnt. Bracket mini-PC / NUC  
RISE A122

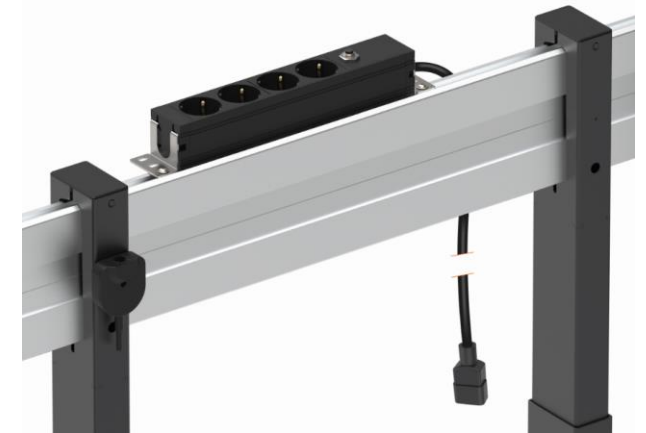

Power socket A152 mounted  
to top of PFB bar

# Accessories for hardware below screen

Accessory interface

+

Accessory

=

End result



Accessory interface

RISE A 111

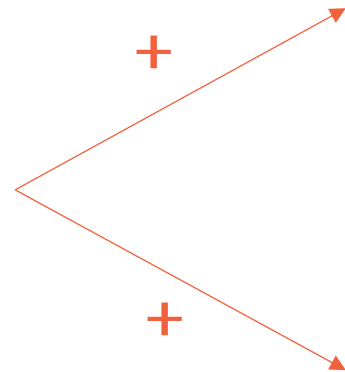

Soundbar  
bracket

RISE A 121



Laptop support

RISE A 131



# Accessories for hardware above screen

Accessory interface

+

Accessory

=

End result



Accessory interface

RISE A111

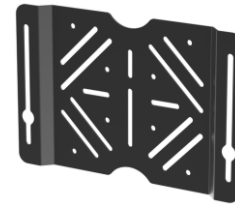
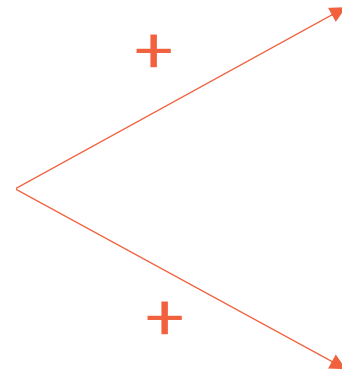

Mounting bracket  
small VC camera's

RISE A142



Camera support for larger  
camera's

RISE A141

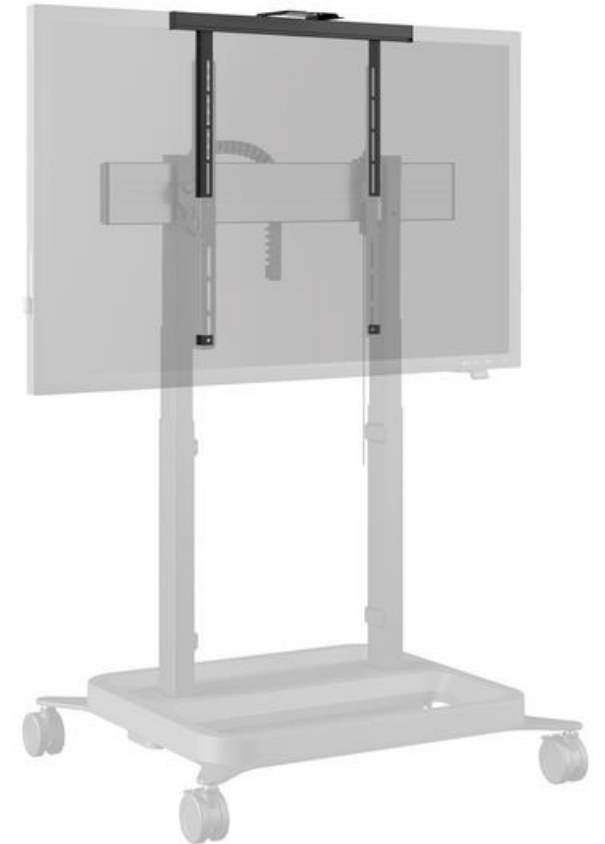

# Installation accessories

- Basic STUD wall adapter (RISE A 112)
- Flexible STUD wall adapter (RISE A 164)
- Extended wall brackets (RISE A 161 7-13cm & RISE A 162 13-19cm)
- Vertically flexible wall brackets (RISE A 163)
- VESA 1000 accessories (RISE A 172 – A 173 – A 174)

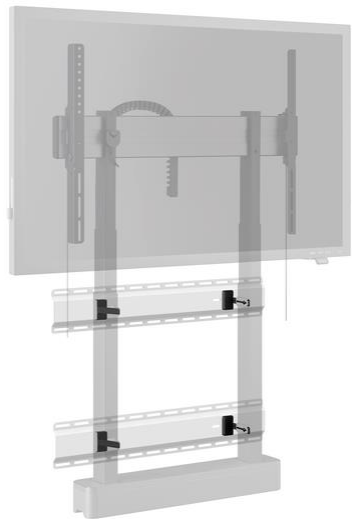

Basic STUD wall adapter  
RISE A 112

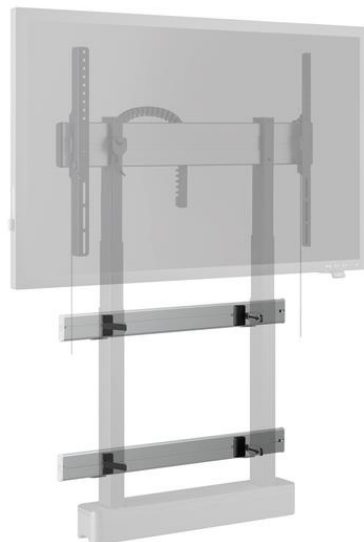

Flexible STUD wall adapter  
RISE A 164



Extended wall brackets  
RISE A 161 & RISE A 162 (black and white)



Extended wall brackets  
RISE A 163 (black and white)

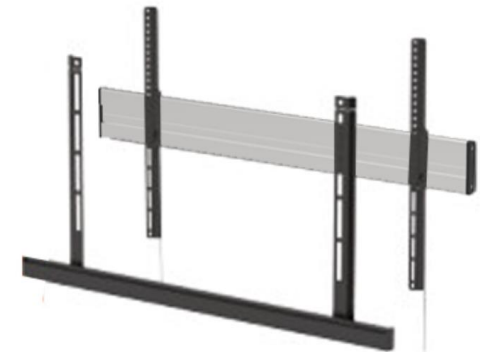

VESA 1000 bar (A 171) VESA 800 strip  
(A 172) & interface rail 1000 VESA (A 174)





**RISE**  
**Expected 2025**

## RISE 4105 – Floor supported wall mount with flat floor plate

- Displays up to 86"
- Max. 120KG
- 700 mm stroke
- 50mm/s or 80mm/s
- Available in black
- Cable management
- Whiteboards up to 86"
- Wide range of accessories
- Anti-collision
- CE, TUV, GS & ADA certified
- Available 1st of April 2025



# RISE Direct Control

Move your display with the touch of your hand!

- Displays up to 98"
- Max. 100KG display weight
- Max. 140KG on RISE 2XXX
- Max. 120KG on trolleys/stands
- Only 80mm/s
- Cable management
- Whiteboards up to 86"
- Wide range of accessories
- Anti-collision
- CE & TUV certified



